

VISIANO
LED EXAMINATION LIGHTS

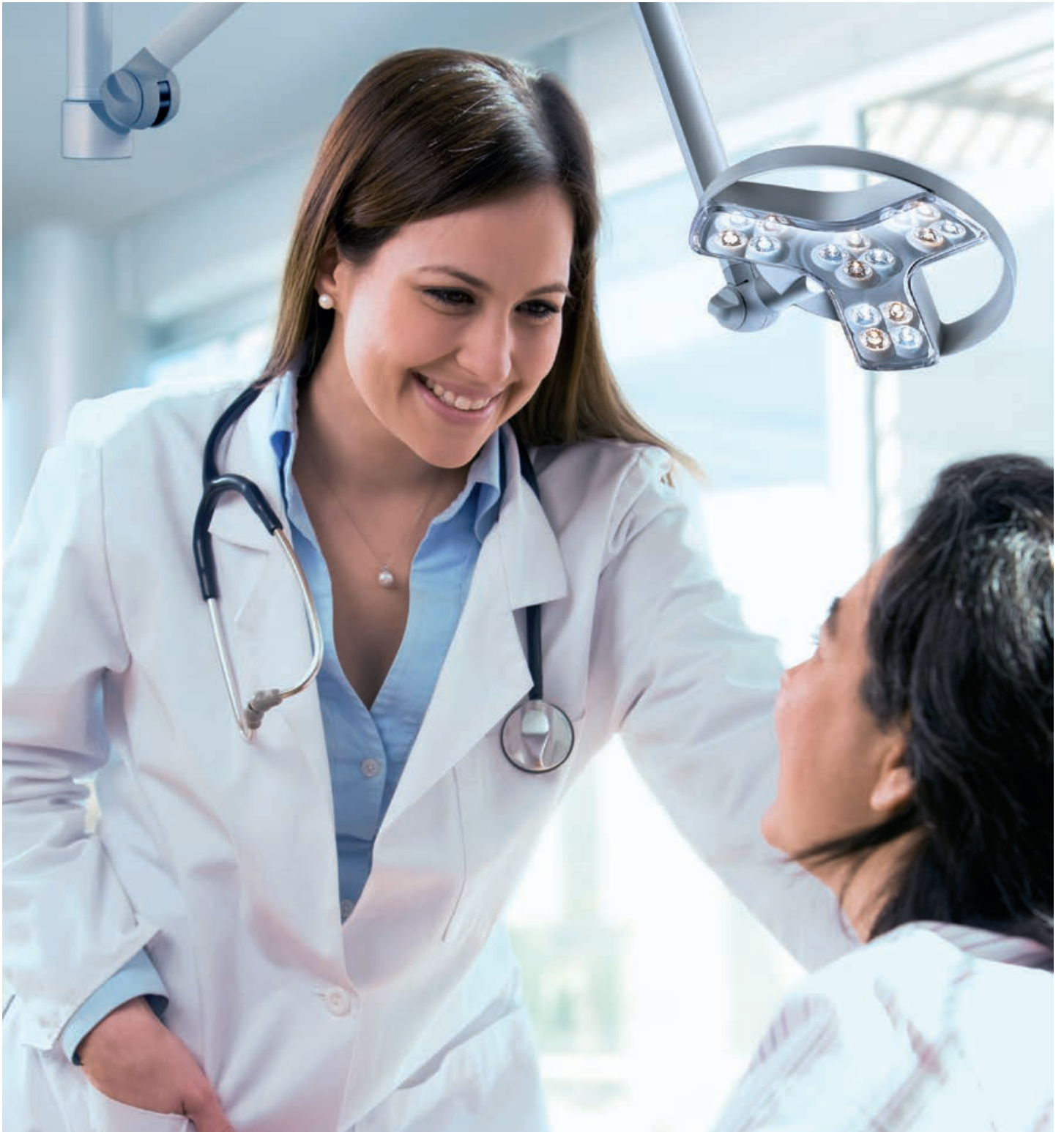

reddot award
winner



UNIQUE DIAMOND
OPTICS:
PREMIUM-LED

VISIANO OUR MASTERPIECE

Wherever it is necessary to have the highest standards of vision, uncompromising lighting is essential. Whether in a GP practice or at the dermatologist's office, in ENT or gynecology and particularly in sensitive wards such as neonatology and intensive care: The VISIANO is versatile and dependable. Thanks to its unique design, modern lighting technology and highest quality of light, it ensures optimal examination conditions.

••••
LED

- Highest lighting quality
Thanks to a concave lighting head design, diamond optics and premium LEDs, homogeneous light field and high illuminance, low shadowing, excellent color rendering (Ra > 95, R13 > 93)
- Long service life, safe and economical
low power consumption, built-in converter, maintenance-free housing, high-quality aluminium arm system and durable friction joints
- Maximum reach and ergonomics
360° rotation of the luminaire head, long arm reach
- Four dimming levels
Repeatable luminous intensities, also as ambient indirect lighting in sensitive areas
- Approved safety
Medical device according to IEC 60601, unique in this class



reddot award 2014
winner

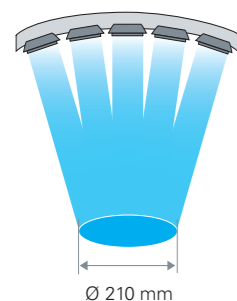

Illumination field
0.5 m, Ø 21 cm

efficient *light*

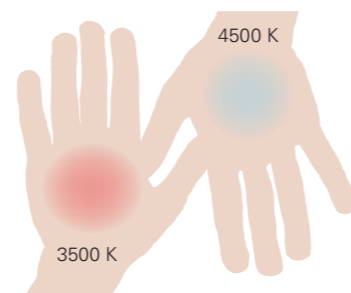

Color change
for optimal contrast sensitivity

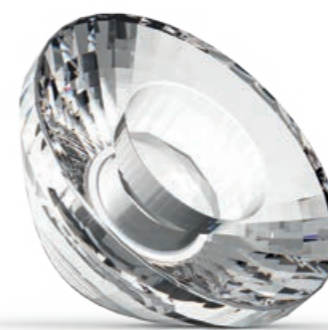

unique diamond optics
for best color uniformity of the light



360° turnover-axis
for maximum light



spring balanced friction joint
effortless positioning and locking



Protection against the spread of bacteria

In untreated materials, harmful bacteria and germs multiply within 20 minutes. The integrated antimicrobial Sanitized® hygiene function in the upper luminaire housing, the control panel and the hand wheels on the joints help to keep critical areas hygienic. Tests have shown that 99% of the bacteria and microbes could be destroyed. The biocide is permanently resistant, but is not a substitute for regular cleaning.

BACTERIA
REDUCTION
WITH SILVER IONS

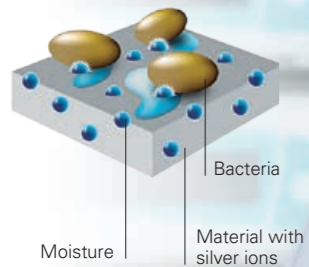

www.sanitized.com

Silver ions destabilize the cell membrane of microbes and bacteria

WANTED – FOUND THE PERFECT EXAMINATION LIGHT



The range of uses of the new VISIANO is as versatile as the selection of mounting options. Whether mounted on the ceiling, wall or floor. While you enjoy its superb ergonomic, the antimicrobial Sanitized® hygiene feature reliably inhibits the growth of microorganisms on the surface. In addition, the fully enclosed housing prevents penetration and the formation of dirt.

VISIANO compact

- intuitive and ergonomic
- high-quality components
- homogeneous light field (Ø 21 cm, 60,000 000 Lux/ 0.5 m)
- built-in antimicrobial hygiene feature
- various fixation options
- color changing
- 4 dimming levels

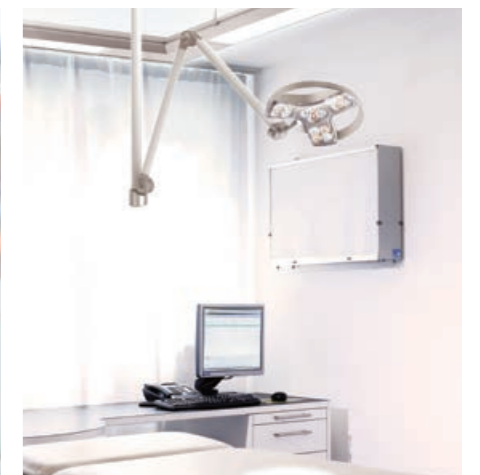

VISIANO



Ceiling tube
max. 116 mm long
(can be cut to length)

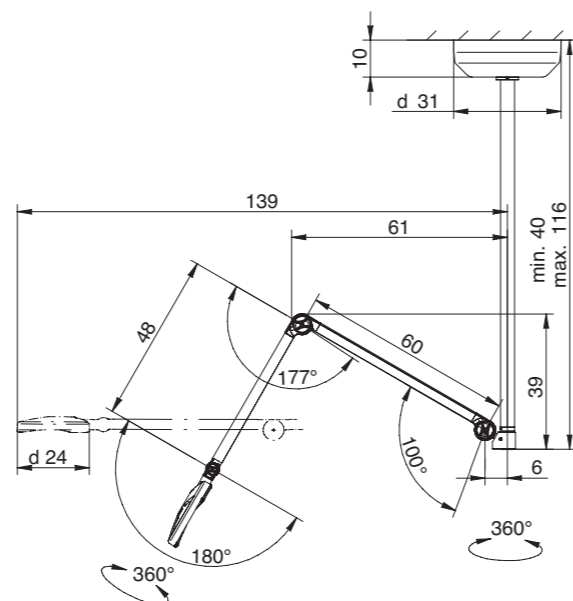

Ceiling version

VISIANO – CEILING VERSION			ORDER NO.
VISIANO 20-2 CT1	pure white / gray	Fixed connection	D15.450.000



Pin version

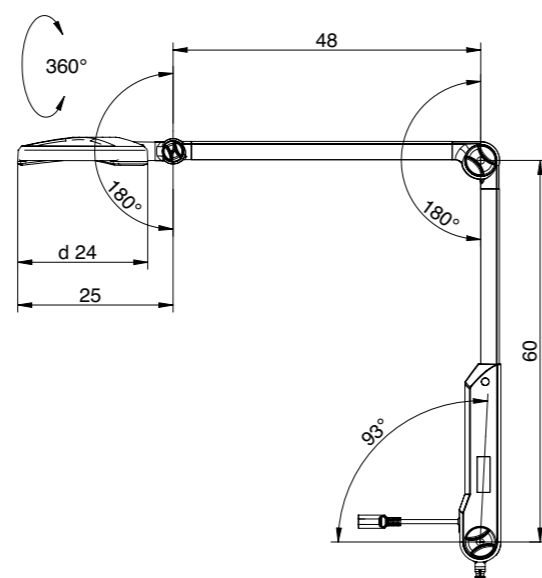

VISIANO – PINVERSION			ORDER NO.
VISIANO 20-2 PTX	pure white / gray	Euro	D15.451.000
VISIANO 20-2 PTX	pure white / gray	UK	D15.456.000

VISIANO technology

Light output	60,000 Lux / 0.5 m *
Color temperature	3500 K & 4500 K *
Illumination field 1.0 m	Ø 21 cm *
Color rendering	Ra > 95
Operation	Control panel at light head
Accessories	Suspended Ceiling Adapter
Protection class	II
Standards	EN 60601-1, EN 60601-2-41
Protection class	IP 20
Features	2 color temperatures, 4 dimming levels, antimicrobial, 360° Turn-over Axis

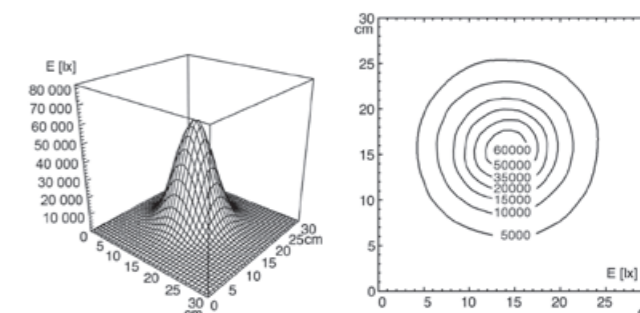

* -10% / +20% tolerance

ACCESSORIES



ROLLERSTAND	
Material	Steel
Finish	- Tube: white - Foot: plastic - Casters: twin plastic casters, with 5 brakes
Dimensions	1.0 m; Ø 700 mm
Weight (net)	7.5 kg
for pin Ø	16 mm-W with removal guard with cable suspension device
Order number	D15.595.000

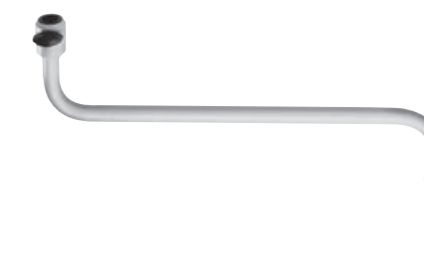

EXTENSION ARM	
Material	Powder-coated steel / steel pipe
Dimensions	400 m, Ø 16 mm
Weight (net)	approx. 0.65 kg
for stud Ø	16 mm with removal protection
Capacity	2.5 kg
Order number	D13.363.000 - pure white



RAIL MOUNTING	
Material	Aluminum
Wall Rail system	25-35 x 8-10 mm
Order number	D13.269.000



TABLE CLAMP	
Material	Polyamide steel
Order number	D14.228.000 - black



WALL BRACKET	
Material	Polyamide GF
Order number	D13.231.000 - pure white

OWN SALES BRANCHES

GERMANY

Herbert Waldmann GmbH & Co. KG
PO Box 5062
78057 Villingen-Schwenningen
Germany
Phone +49 7720 601 100
Fax +49 7720 601 290
www.waldmann.com
sales.germany@waldmann.com

SWEDEN

Waldmann Ljusteknik AB
Skebokvarnsvägen 370
124 50 Bandhagen
SWEDEN
Phone +46 8 990 350
Fax +46 8 991 609
www.waldmann.com
info-se@waldmann.com

SWITZERLAND

Waldmann Lichttechnik GmbH
Benkenstrasse 57
5024 Küttigen
Switzerland
Phone +41 62 839 12 12
Fax +41 62 839 12 99
www.waldmann.com
info-ch@waldmann.com

USA

Waldmann Lighting Company
9, W. Century Drive
Wheeling, Illinois 60090
USA
Phone +1 847 520 1060
Fax +1 847 520 1730
www.waldmannlighting.com
waldmann@waldmannlighting.com

AUSTRIA

Waldmann Lichttechnik Ges.m.b.H
Gewerbepark Wagram 7
4061 Pasching/Linz
Austria
Phone +43 7229 67 400
Fax +43 7229 67 444
www.waldmann.com
info-at@waldmann.com

SINGAPORE

Waldmann Lighting Singapore Pte. Ltd.
22 Cross Street
#02-50/51
South Bridge Court
Singapore 048421
Singapore
Phone +65 6275 8300
Fax +65 6275 8377
www.waldmann.com
sales-sg@waldmann.com

FRANCE

Waldmann Eclairage S.A.S
Z.I. - Rue de l'Embranchement
67116 Reichstett
FRANCE
Phone +33 3 8820 95 88
Fax +33 3 8820 95 68
www.waldmann.com
info-fr@waldmann.com

CHINA

Waldmann Lighting (Shanghai) Co. Ltd.
Part A11a, No. Five Normative Workshop
199 Changjian Road, Baoshan
Shanghai, P.R.C. 200949
China
Phone +86 21 5169 1799
Fax +86 21 3385 0032
www.waldmann.com
info@waldmann.com.cn

ITALY

Waldmann Illuminotecnica S.r.l.
Via della Pace, 18 A
20098 San Giuliano Milanese (MI)
Italy
Phone +39 02 98 24 90 24
Fax +39 02 98 24 63 78
www.waldmann.com
info-it@waldmann.com

INDIA

Waldmann Lighting PVT. Ltd.
Plot No. 52
Udyog Vihar
Phase-VI, Sector-37
GURGAON-122001, Haryana
India
Phone +91 124 412 1600
Fax +91 124 412 1611
www.waldmann.com
sales-in@waldmann.com

NETHERLANDS

Waldmann BV
Lingewei 19
4004 LK Tiel
Netherlands
Phone +31 344 631 019
Fax +31 344 627 856
www.waldmann.com
info-nl@waldmann.com



Sydney | Melbourne | Brisbane | Perth

1300HPAUST
info@hpaust.com
www.hpaust.com



75 years
Derungs

Derungs Licht AG is a member of the Waldmann Group.